



3-2750.090

Rev. H 04/09

English

WARNING!



SAFETY INSTRUCTIONS

1. Depressurize and vent system prior to installation or removal.
2. Confirm chemical compatibility before use.
3. Do not exceed maximum temperature/pressure specifications.
4. Wear safety goggles or faceshield during installation/service.
5. Do not alter product construction.
6. When using chemicals or solvents care should be taken and appropriate eye, face, hand, body, and/or respiratory protection should be used.

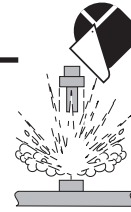

1. Description
2. Specifications
3. In-line Installation
4. 2750 In-line Assembly
5. Submersible Installation
6. Digital (S³L) wiring
7. 4-20 mA Loop wiring
8. Calibration
9. Troubleshooting
10. Ordering Information

1. Description

Signet 2750 pH/ORP Sensor Electronics provide two-wire 4 to 20mA loop output for pH and ORP measurements, without the expense of local display and other luxuries available in full-featured transmitters. Preamplification is built-in, reducing system costs while ensuring absolute signal integrity up to 304.8m/1,000 feet.

These sophisticated field-mount devices also provide the digital (S³L™: Signet Sensor Serial Link) output; the latest development in leading-edge technology from Signet. The 2750 Sensor Electronics self-configure for pH or ORP operation via automatic recognition of electrode type, and the DryLoc electrode connector quickly forms a robust assembly for submersible and in-line installations.

NEMA 4X Junction Boxes are integral parts of the in-line version and are available as accessories for the submersible version. The optional Easy-Cal feature allows simple push-button calibration and includes an LED for visual feedback.

2. Specifications

General

- Compatible Electrodes: Signet DryLoc Electrodes. (PT1000 temperature sensor versions for pH)
- Operational Range: 0.00 to 14.00 pH, ±2000 mV ORP
0°C to 85°C (32°F to 185°F)
- Response Time (includes electrode response):
pH: <6 s for 95% of change
ORP: application dependent
pH Temp τ: 140 s (2754)
196 s (2756)
438 s (2756-WT)

Materials:

- 2750-1, -2 (in-line): PBT (thermal plastic polyester)
2750-3, -4 (submersible): CPVC

Cable for -3, -4 submersible versions:

- 5 m (15 ft.) 3-conductor shielded, 22 AWG.
- May be extended up to 183 m (600 ft) with current output.
- May be extended up to 305 m (1000 ft) with S³L output.

Weight:

- 2750-1, -2 (in-line): 0.75 kg (1.75 lb.)
2750-3, -4 (submersible): 0.64 kg (1.4 lb.)

Environmental

- Ambient Temp.: -10°C to 85°C
- Storage Temp.: -20°C to 85°C
- Relative Humidity: 95% max, non-condensing
- Immunity: EN50082-2
- Emissions: EN50081-1
- Enclosure Rating:
2750-1, -2 (in-line): NEMA 4X/IP65 (with electrode connected)
2750-3, -4 (submersible): NEMA 6P/IP68 (with electrode and watertight extension pipe)

connected)

Electrical

- Input Impedance: >10¹¹Ω
- Input response time: 500 ms
- Temperature drift: ±0.002 pH per °C
±0.1 mV ORP per °C
- Input resolution: 0.02 pH, 1 mV ORP, 0.3°C

Current output:

- Description: pH: Fixed 4 to 20 mA, isolated, 0 to 14 pH (custom scaling available)
ORP: Fixed 4 to 20 mA, isolated, -1000 to 2000 mV (custom scaling available, -2000 to 2000 mV)
- Power: Regulated 12-24 VDC ± 10%, 20 mA max.
- Max Loop Resistance: 50Ω max. @ 12V
325Ω max. @ 18V
600Ω max. @ 24V
- Accuracy: ±32µA @ 25°C
- Temperature drift: ±1µA per °C
- Output resolution: ± 5 µA
- Error indication: 3.6 mA

Digital (S³L) output:

- Description: Serial ASCII, TTL level 9600 bps
- Power: 5VDC ± 10% regulated, 3 mA max
- Accuracy: pH: ± 0.03 pH @ 25°C
ORP: ± 2 mV @ 25°C
- Resolution: pH: 0.02 pH
ORP: 1 mV
Temp: 0.2°C
- Error indication: Temp output "+999.9"

Standards and Approvals

- CE
- Manufactured under ISO 9001 and ISO 14001
- Chinese RoHS (Go to www.gfsignet.com for details)

3. In-line Dimensions

- The 2750-1 in-line sensor (without Easy-Cal) is designed for applications where electrode calibration is facilitated by remote equipment.
- The 2750-2 In-Line sensor includes Easy-Cal.
- A Signet installation fitting (1/2 in. to 4 in.) or a Signet pipe adapter is required to secure the electrode in the pipe.
- The Signet Measurement and Instrumentation catalog offers a complete selection of fittings.
- The 2750-3 and 2750-4 submersible sensor electronics are recommended for in-line applications using the 2764 series differential electrodes and the 2774 series Threaded DryLoc electrodes.
- 2764 and 2774 series electrodes thread directly into standard 1 in. or 3/4 in. NPT fittings.

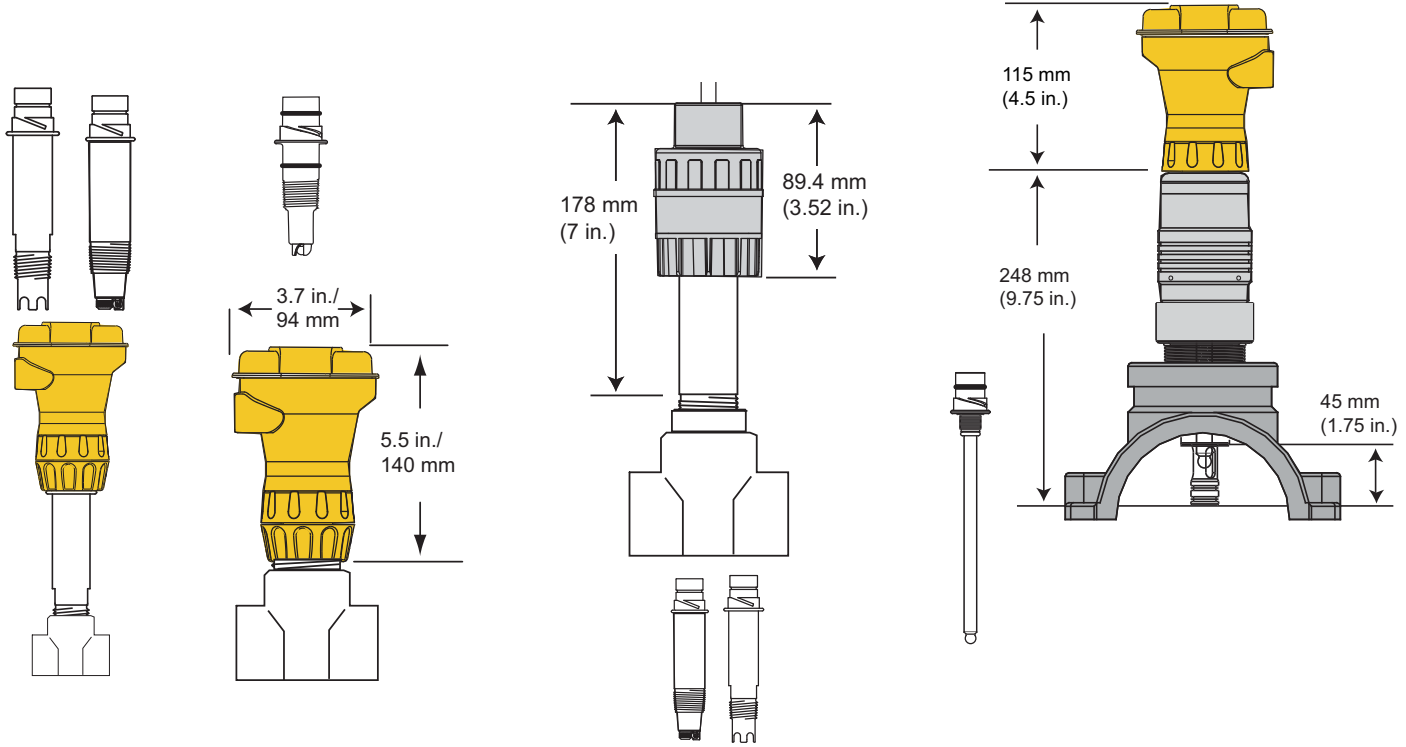

Mounting position

2754 and 2764 series electrodes must be mounted upright.

- Vertical (0°) position optimum
- Do not install within 30° of horizontal (Contact factory for horizontal or inverted installation requirements.)
- Recommended maximum flow rate 10 ft/s.
- Wet-tap electrodes, 2724, and 2774 series electrodes can be mounted at any angle.

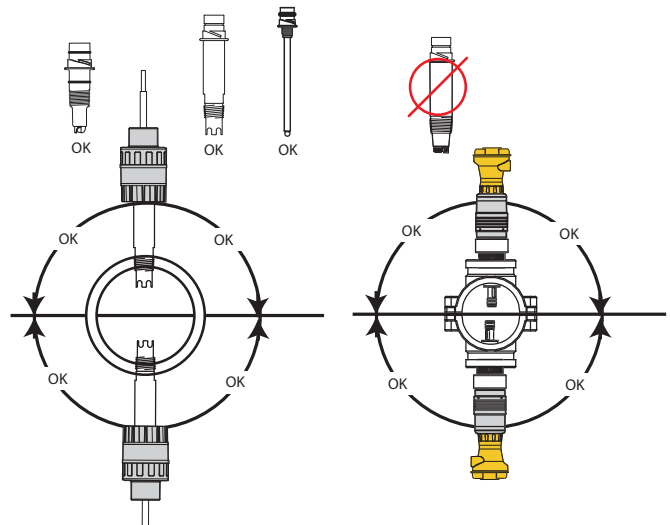
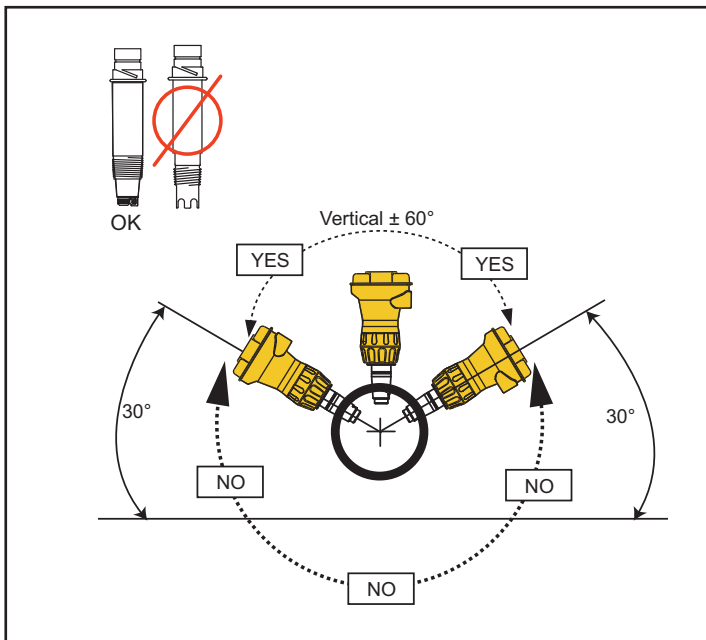

4. 2750 In-line pH Sensor Assembly

Note: This procedure applies to systems using standard 2754-2757 and 2724-2726 electrodes. If the 3719 pH/ORP Wet-Tap is used, refer to the 3719 manual for instructions.

1. Insert electrode into Signet installation fitting. Seat the electrode tabs into the alignment notches in the fitting.

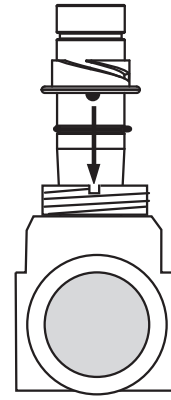

2. Thread the in-line retaining cap onto fitting to secure the electrode into place.

Retaining cap



HAND-TIGHTEN THE THREADED NUT ONTO THE INSTALLATION FITTING. DO NOT USE TOOLS! DO NOT USE THREAD SEALANT OR LUBRICANTS ON THE FITTING THREADS OR THE SENSOR CAP.

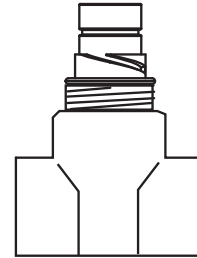

Note:

Keep the electrical interconnection between electrode and sensor electronics dry and clean at all times.

3. Unlock the ring on base of 2750 (The ring is unlocked when the lines on the ring and body of the 2750 are not aligned.)

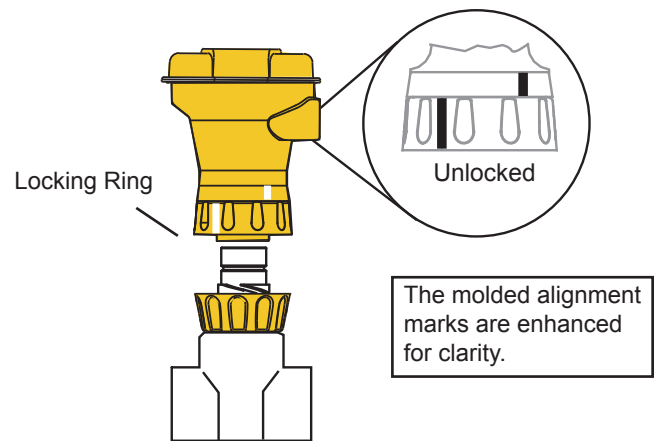

4. Place 2750 onto top of electrode and turn until the assembly drops into position.
5. Turn locking ring $\frac{1}{4}$ turn to secure the 2750 assembly. (The ring is locked when the line on the ring and the line on the body of the 2750 are aligned.)

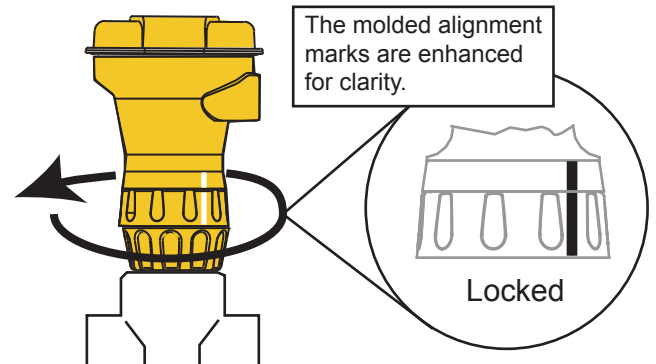

In-Line Sensor and Electrode Removal

- **To remove electronics assembly only:**
Turn locking ring $\frac{1}{4}$ turn; lift assembly straight up.
- **To remove electrode from the pipe:**
Remove electronics assembly, then unthread retaining cap; pull electrode straight up.
- **To remove the complete 2750 system:**
Hold locking ring in place. Unthread retaining cap and pull electrode straight up.



CAUTION!

- Do not remove the electrode from a pressurized pipe.
- Wear appropriate protective clothing when working with chemicals in pressurized pipe.

5. 2750-3, -4 Submersible Sensor Assembly and Installation

1. Insert electrode into base of the 2750-3 or 2750-4 and turn until keyed contacts are seated.
2. Thread retaining cap over electrode and hand-tighten onto 2750.
3. Attach $\frac{3}{4}$ in. watertight pipe to the top of the 2750. Secure the threaded connection to prevent any leakage.
 - For additional defense against possible accumulation of condensation at the back seal area of the sensor, fill the lower 3-4 inches (75-100 mm) of conduit or extension pipe with a flexible sealant such as silicone.

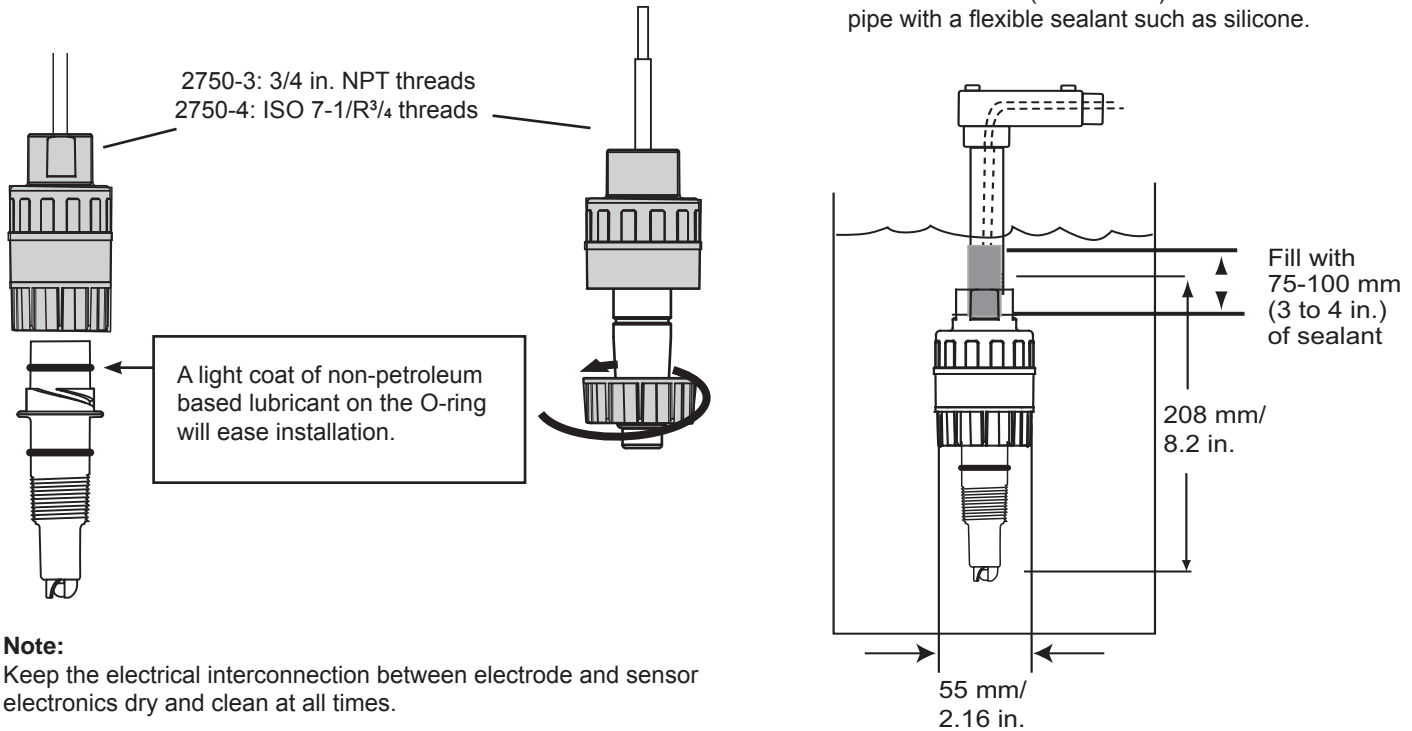

Note:

Keep the electrical interconnection between electrode and sensor electronics dry and clean at all times.

Use standard installation hardware to connect the submersible 2750-3 or -4 directly to external equipment.

OR

The 8052-1 NPT Mount Junction box (or 8052-2 with Easy-Cal) connects to $\frac{3}{4}$ in. pipe or conduit and provides convenient wiring termination.

OR

The 8050-1 Universal Mount junction box (or 8050-2 with Easy-Cal) mounts flat onto a wall or can be strapped to a post or pipe.

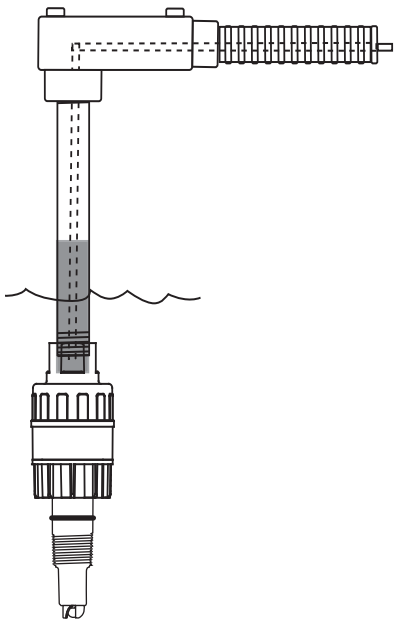

Cable supplied: 5 m (15 ft.) 3-conductor + shld, 22 AWG. May be extended up to 183 m (600 ft) with current output. May be extended up to 305 m (1000 ft) with digital (S³L) output.

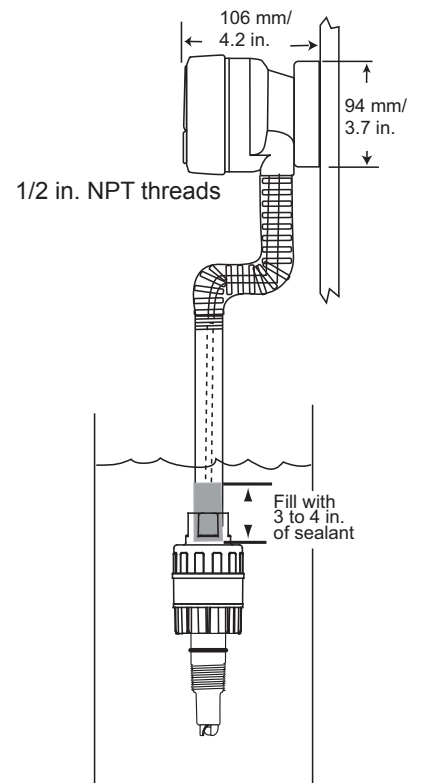
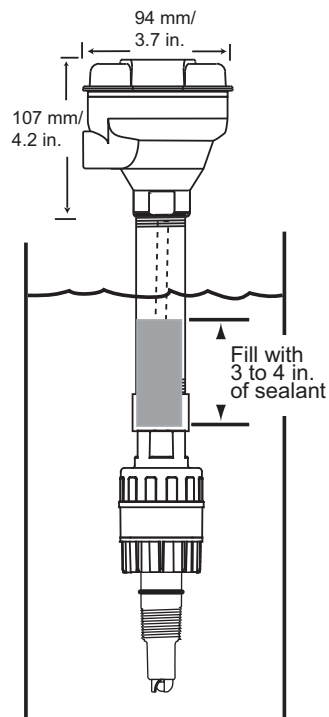

6. Digital (S³L) wiring

- When the 2750 is powered with 5 VDC, the digital (S³L) serial data output is automatically selected.
- S³L data is used exclusively by Signet instruments.
- Remove approximately 10 mm (0.4 in.) of insulation and tin each conductor before inserting into connectors.

S³L with no junction box

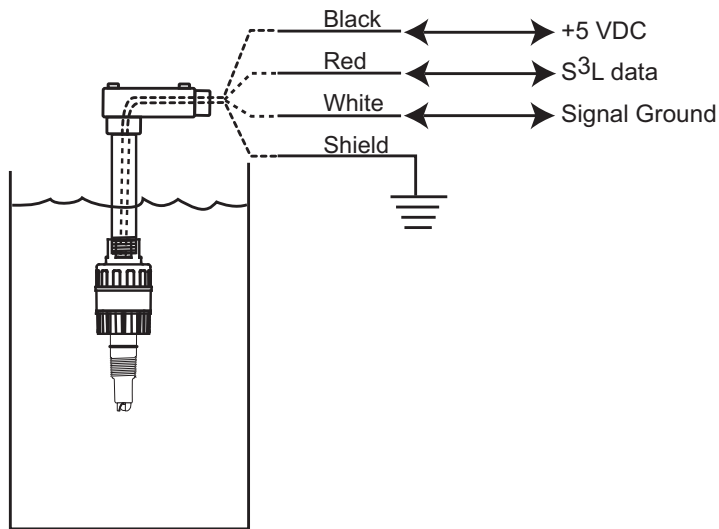

- Connect the 2750 cable directly to S³L I/O terminals.
- **8900 users:** If this direct wiring is used, set the CALIBRATE menu to "perform calibration at INSTRUMENT"

S³L with Junction box

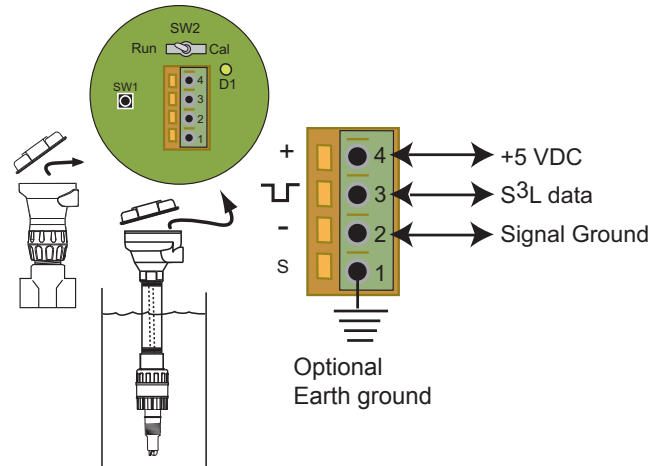

- When the 2750 includes a terminal block, connect the 2750 terminals as shown to any S³L I/O port.
- **8900 users:** If the 2750 includes the Easy-Cal accessory, set the CALIBRATE menu to "perform Calibration at either SENSOR or INSTRUMENT"
- If SENSOR, use standard pH buffer values (pH 4, 7, or 10) to perform periodic calibration.
- If INSTRUMENT, any pH value can be used.

7. 4-20 mA Loop wiring

- When the 2750 is powered with 12 to 24 VDC, the 4-20 mA loop output is automatically selected.
- Remove approximately 10 mm (0.4 in.) of insulation and tin each conductor before inserting into connectors.

Current Loop with no junction box

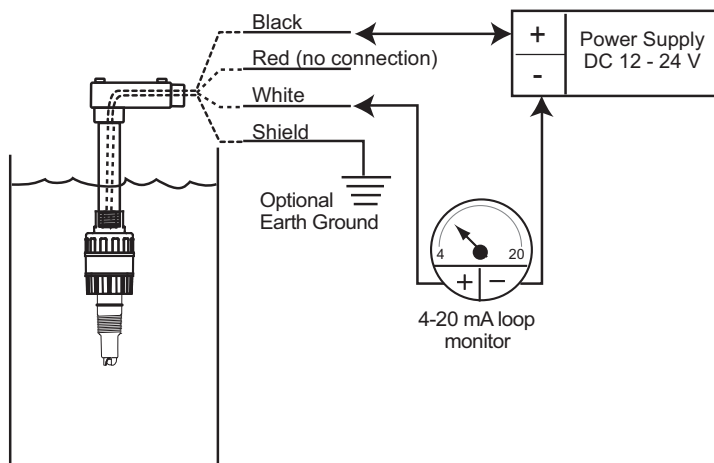

- Connect the 2750 cable directly to a Loop device as shown.
- This configuration does not provide any calibration capability within the 2750 system. Periodic calibration must be performed at the external equipment.

Current loop with Junction box

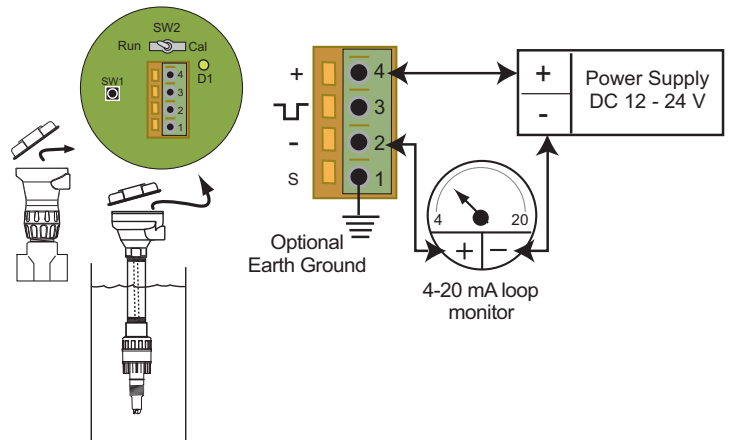

- When the 2750 includes a terminal block, connect the 2750 terminals to the Loop device as shown.
- If the 2750 includes the Easy-Cal accessory, use standard pH buffer values (pH 4, 7, or 10) to perform periodic calibration.

8. Calibration

All 2750 pH/ORP Sensor Electronics are factory-calibrated for maximum out-of-the-box accuracy. Periodic calibration is required to compensate for electrode aging.

The optional Easy-Cal feature allows calibration to be performed local to the sensor.

SW1 Easy-Cal button
SW2 RUN/CALIBRATE switch for S³L system
D1 Easy-Cal Indicator (green LED)

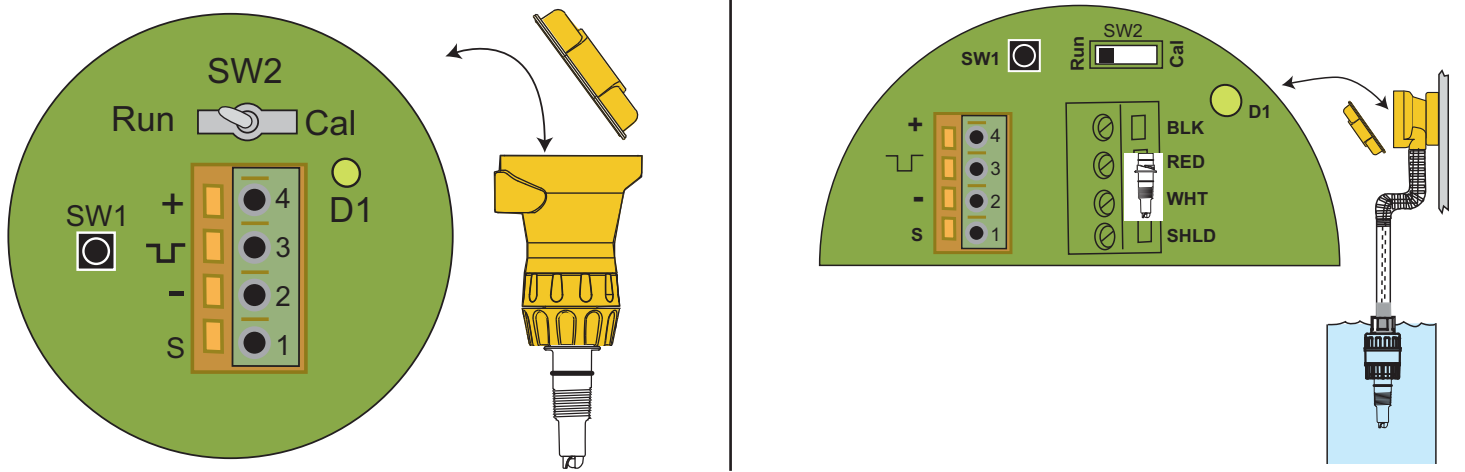

Easy-Cal Procedure:

The first step (Reset) is recommended each time an electrode is replaced, but is NOT necessary upon initial installation or periodic calibration. In fact, for periodic calibration it is best for the electrode/sensor assembly to remain intact to minimize the possibility of moisture or other contamination entering the electrical interconnection area. The electrode/sensor connection must remain dry and clean at all times.

1. Reset the 2750 pH/ORP Sensor to factory calibration: With no electrode connected to the Sensor, press and hold SW1 until the LED (D1) comes on steady then goes off again (approx. 10 seconds). When the LED goes off, release SW1; reset is complete.
2. Connect an electrode to the 2750 pH/ORP Sensor.
3. **If S³L output is being used, place SW2 in the "Cal" position. If 4-20 mA output is being used, SW2 position is of no consequence.**
4. Place the electrode/sensor assembly into a calibration solution as follows: (If the electrode is "healthy", then the 2750 will automatically recognize the solution. The order in which the solutions are used during the calibration procedure is of no consequence.)
 - For pH calibration, use any two of these international standards: pH 4.0, 7.0 or 10.0 buffer solutions. (Signet part number 3-0700.390 contains one capsule of each value)
 - To produce standards for ORP calibration, mix the chemical Quinhydrone into pH 7.0 and 4.0 buffers to saturation (1/8g per 50ml).
 - Regardless of the size of the container used for calibration, one inch of solution is adequate to completely submerge the tip of the electrode.
 - **Allow at least 30 seconds for the electrode response to stabilize before calibration.**
5. Press and hold SW1 for approximately 8 to 10 seconds. During this time, the LED (D1) will come on steady then go back off. Release SW1 (If the LED blinks several times rapidly, the calibration was not successful. See the troubleshooting section.)
6. Remove the electrode/sensor assembly from the first calibration solution, rinse the electrode with clean water, and place it in a second solution.
 - **Allow at least 30 seconds for the electrode response to stabilize before calibration.**
7. Press and hold SW1 for approximately 8 to 10 seconds. During this time, the LED will come on steady then go back off. Release SW1. (If the LED blinks several times rapidly, the calibration was not successful. See the troubleshooting section.)
8. **For S³L systems ONLY: Return SW2 to the RUN position.**

Calibration is complete. Return the system to service.

9. Troubleshooting

LED and Output Condition	Possible Causes	Suggested Solutions
Current Out: LED off, current output is 3.6 mA S³L: Temp out is +999.9	<ul style="list-style-type: none"> No electrode installed Bad/dirty contacts between electrode and 2750 	<ul style="list-style-type: none"> Install electrode Check interconnection between electrode and 2750, clean contacts
During Easy-Cal, the LED blinks rapidly for 4 seconds and the current output is frozen at a random fixed value.	<ul style="list-style-type: none"> The buffer solution is outside of the accepted tolerance for the 2750 The electrode is depleted (> 1.1 pH or 65 mV offset) 	<ul style="list-style-type: none"> pH system: Use fresh 4 pH, 7 pH, or 10 pH buffer and restart the calibration. ORP system: Use fresh 4pH and 7 pH buffer solution saturated with quinhydrone. Replace the electrode.
After completing calibration procedure, the output values are inaccurate.	<ul style="list-style-type: none"> Insufficient time allowed for electrode stabilization during calibration. 	<ul style="list-style-type: none"> Recalibrate, verify that test solutions are at room temperature and wait at least 30 seconds after placing electrode in solution before pressing S1 EasyCal button.

10. Ordering Information

Mfr. Part No.	Code	Description
3-2750-1	159 000 744	In-line Sensor Electronics w/Junction Box
3-2750-2	159 000 745	In-line Sensor Electronics w/Junction Box and Easy-Cal
3-2750-3	159 000 746	Submersible Sensor Electronics with 15 ft. cable, 3/4 in. NPT threads
3-2750-4	159 000 842	Submersible Sensor Electronics with 15 ft. cable, ISO 7-1/R3/4 threads

Parts and Accessories

Mfr. Part No.	Code	Description
DryLoc pH Electrodes		
3-2724-00	159 001 547	Flat pH Electrode, DryLoc, PT1000, 3/4 in. NPT or Signet fittings
3-2724-01	159 001 548	Flat pH Electrode, DryLoc, PT1000, ISO 7/1 R3/4 or Signet fittings
3-2726-00	159 001 555	Bulb pH Electrode, DryLoc, PT1000, 3/4 in. NPT or Signet fittings
3-2726-01	159 001 556	Bulb pH Electrode, DryLoc, PT1000, ISO 7/1 R3/4 or Signet fittings
3-2726-HF-00	159 001 551	Bulb pH Electrode, DryLoc, PT1000, HF resistant, 3/4 in. NPT or Signet fittings
3-2726-HF-01	159 001 552	Bulb pH Electrode, DryLoc, PT1000, HF resistant, ISO 7/1 R3/4 or Signet fittings
3-2726-LC-00	159 001 559	Bulb pH Electrode, DryLoc, PT1000, Low conductivity, 3/4 in. NPT or Signet fittings
3-2726-LC-01	159 001 560	Bulb pH Electrode, DryLoc, PT1000, Low conduct., ISO 7/1 R3/4 or Signet fittings
3-2754	159 000 747	Electrode, pH, DryLoc, flat, PT1000
3-2754-HF	159 000 748	Electrode, pH, DryLoc, flat, PT1000, HF-resist (<2%)
3-2756	159 000 750	Electrode, pH, DryLoc, bulb, PT1000
3-2756-DI	159 000 751	Electrode, pH, DryLoc, bulb, PT1000, DI (<100 µS)
3-2756-WT	159 000 834	Electrode, pH, DryLoc, bulb, PT1000, wet-tap
3-2756-WTP	159 001 390	Electrode, pH, DryLoc, bulb, PT1000, wet-tap
3-2764-2	159 000 944	Electrode, pH, DryLoc, flat, PT1000, differential, 1 in. NPT process connection
3-2766-2	159 000 950	Electrode, pH, DryLoc, bulb, PT1000, differential, 1 in. NPT process connection
3-2774-1	159 000 956	Electrode, pH, DryLoc, flat, PT1000, 3/4 in. NPT process connection
3-2776-1	159 000 960	Electrode, pH, DryLoc, flat, PT1000, 3/4 in. NPT process connection

Mfr. Part No.	Code	Description
DryLoc ORP (Redox) Electrodes		
3-2725-60	159 001 561	Flat ORP Electrode, 10KΩ ID, 3/4 in. NPT or Signet installation fittings
3-2725-61	159 001 561	Flat ORP Electrode, 10KΩ ID, 3/4 in. ISO 7/1 R3/4 or Signet installation fittings
3-2755	159 000 749	Electrode, ORP, DryLoc, flat, 10KΩ ID
3-2757	159 000 752	Electrode, ORP, DryLoc, bulb, 10KΩ ID
3-2757-WT	159 000 835	Electrode, ORP, DryLoc, bulb, 10KΩ ID, wet-tap
3-2765-1	159 000 946	Electrode, ORP, DryLoc, flat, 10KΩ ID, differential, 1 in. NPT process connection
3-2767-1	159 000 952	Electrode, ORP, DryLoc, bulb, 10KΩ ID, differential, 1 in. NPT process connection
3-2775	159 000 957	Electrode, ORP, DryLoc, flat, 10KΩ ID, 3/4 in. NPT process connection
3-2777	159 000 961	Electrode, ORP, DryLoc, bulb, 10 KΩ ID, 3/4 in. NPT process connection
Miscellaneous Accessories		
3-8050-1	159 000 753	Universal Mount Junction Box
3-8050-2	159 000 754	Universal Mount Jct. Box w/Easy-Cal
3-2759	159 000 762	pH/ORP Simulator/System tester
3-2759.391	159 000 764	Adapter cable to connect 2759 and 2750
P31515-0P200	159 000 630	Universal Pipe Adapter PVC
P31515-0C200	159 000 631	Universal Pipe Adapter CPVC
P31515-0V200	159 000 459	Universal Pipe Adapter PVDF
5523-0322	159 000 761	Cable, 3-conductor + shield (blk/red/wht/shld) 22AWG (per ft)
3-0700.390	198 864 403	pH Buffer Kit
3822-7004	159 001 581	pH 4.01 buffer solution, 1 pint (473 ml) bottle
3822-7007	159 001 582	pH 7.00 buffer solution, 1 pint (473 ml) bottle
3822-7010	159 001 583	pH10.00 buffer solution, 1 pint (473 ml) bottle
3822-7115	159 001 606	20 gram bottle Quinhydrone for ORP calibration
3-2700.395	159 001 605	Calibration kit: included 3 PP cups, cup stand, 1 pint pH 4.01, 1 pint pH 7.00



Georg Fischer Signet LLC, 3401 Aerojet Avenue, El Monte, CA 91731-2882 U.S.A. • Tel. (626) 571-2770 • Fax (626) 573-2057
 For Worldwide Sales and Service, visit our website: www.gfsignet.com • Or call (in the U.S.): (800) 854-4090

